

SKIRTING 100

POLISHED and SATINED
STAINLESS STEEL AISI 304/1.4301-V2A

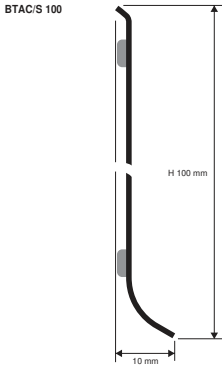

SKIRTING made in stainless steel AISI 304/1.4301-V2A in height 100 mm. Available with or without adhesive. Superior aesthetic quality, extremely strong and easy to lay, it is ideal for all public and private environments that require high standards of hygiene and image. Used increasingly more often in contrast combinations with wood, carpeted floors, etc. for an unmistakable hi-tech effect. In order to facilitate and to perfect the laying process, internal and external angles, plugs and junctions are recommended.



POLISHED STAINLESS STEEL AISI 304/1.4301-V2A with protective film
bar length 2 LM - pack: 20 Pcs - 40 LM

Article	H mm		
BTAC 100A (with adhesive)	100		
BTAC 100 (without adhesive)	100		

SATINED STAINLESS STEEL AISI 304/1.4301-V2A with protective film
bar length 2 LM - pack: 20 Pcs - 40 LM

Article	H mm		
BTACS 100A (with adhesive)	100		
BTACS 100 (without adhesive)	100		

EXAMPLES OF LAYING

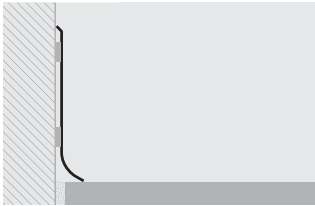

SUITABLE FOR USE IN CONTACT WITH FOODSTUFFS

LAYING INSTRUCTIONS

1. Choose the skirting also choose with or without adhesive. 2. Cut the profile to the required length, taking care to calculate the width of the inside-outside corner joints. 3. For the self-adhesive version, the surface must be smooth, grease-free and not porous. It is not recommended for plaster and mortar surfaces (version without adhesive is better, using fast-setting acrylic silicone which is suitable for fixing aluminium to mortar - plaster, etc.). 4. Use the corner linking elements-joints and right and left end caps to facilitate laying.

COLOURS



(for a precise assessment of colours and finishes, see the relative enclosed sheet)

IN/OUTSIDE CORNERS, JOINTS/CONNECTOR, END CAPS

PAINTED PLASTIC (polished chrome finish, is best suited for POLISHED STAINLESS STEEL) and SATINED STAINLESS STEEL

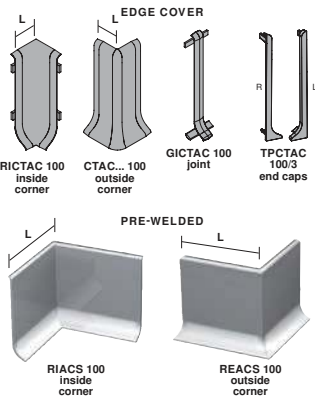

EDGE COVER CORNERS

printed plastic

IN/OUTSIDE CORNER - EDGE COVER
POLISHED STEEL EFFECT - pack: 5 Pcs

Article	H x L mm		
RICTAC 100 (inside)	100 x 20		
RECTAC 100 (outside)	100 x 20		

JOINTS - EDGE COVER - POLISHED STEEL EFFECT
pack: 5 Pcs

Article	H mm		
GICTAC 100	100		

END CAPS R / L - EDGE COVER - POLISHED STEEL EFFECT
pack: 6 Pcs (3 right and 3 left)

Article	H mm		
TPCTAC 100/3	100		

EDGE COVER CORNERS

printed plastic

IN/OUTSIDE CORNER - EDGE COVER
SATINED ST. STEEL EFFECT - pack: 5 Pcs

Article	H x L mm		
RICTACS 100 (inside)	100 x 20		
RECTACS 100 (outside)	100 x 20		

JOINTS - EDGE COVER - SATINED ST. STEEL EFFECT
pack: 5 Pcs

Article	H mm		
GICTACS 100	100		

END CAPS R / L - EDGE COVER - SATINED ST. STEEL EFFECT
pack: 6 Pcs (3 right and 3 left)

Article	H mm		
TPCTACS 100/3	100		

FLUSH CORNERS

satined stainless steel AISI 304/1.4301-V2A

IN/OUTSIDE CORNER - PRE-WELDED
SATINED STAINLESS STEEL - pack: 5 Pcs

Article	H x L mm		
RIACS 100 (inside)	100 X 50		
REACS 100 (outside)	100 X 50		